

# D C Norris & Company

At the forefront of food handling and process technology

## 370 PUMP FILL STATION

Stand-alone unit for the accurate batching of product into pouches ready for cooking or cooling.

### CapKold process

- All stainless steel construction
- PLC control
- Stored pouch/product volumes
- HMI panel or push button "self teach" options
- Temperature cut-out to prevent cold filling of bags
- Clipping head with 'no-clip' alarm
- Pumps solids (35 mm) with no product damage
- Positive rotary pump
- Data logging (optional)
- Load cell (optional)
- CIP incorporation (optional)



The model shown has a user friendly HMI panel but the unit is also available as a "self teach" option with simple push button controls.

The CapKold system of food preparation, storage and distribution can deliver consistent quality and fresh cooked flavour in meals prepared days, or even weeks earlier.

**DCN On-Site Test Kitchen Facility Available for Product Development, Trials & Hire**

**Book Your Trial Now!**

**For further details and for the full range of DCN food processing equipment contact:**

Sales Office, D C Norris & Company Ltd,  
Tel: +44 (0)1767 677 515 Fax: +44 (0) 1767 677956

Email: [sales@dcnorris.co.uk](mailto:sales@dcnorris.co.uk)

Or visit our web-site [www.dcnorris.co.uk](http://www.dcnorris.co.uk)



# D C Norris & Company

At the forefront of food handling and process technology

## Technical Data

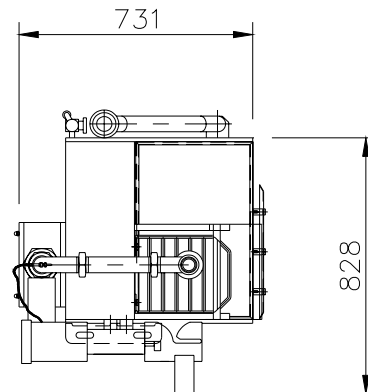
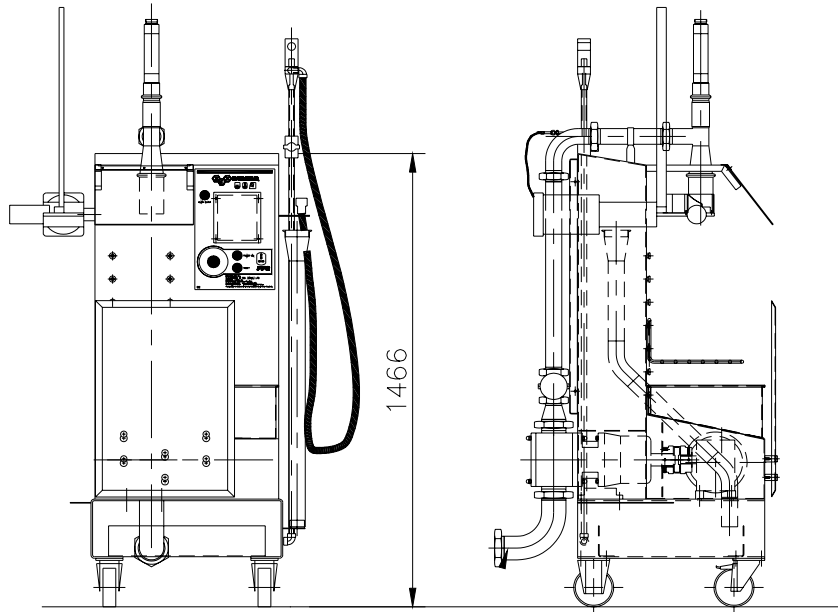

	Requirement	Connection
Air	5 l/min @ 6 Bar	1/2" BSP
Voltage	220 VAC-16A	20 mm
Product	Gravity Feed	3" RJT/IDF

Height	Width	Length	Weight (Kg)
1940	828	731	250



**For further details and for the full range of DCN food processing equipment contact:**

Sales Office, D C Norris & Company Ltd,

Tel: +44 (0)1767 677 515 Fax: +44 (0) 1767 677956

Email: [sales@dcnorris.co.uk](mailto:sales@dcnorris.co.uk)

Or visit our web-site [www.dcnorris.co.uk](http://www.dcnorris.co.uk)