

# D C Norris & Company

At the forefront of food handling and process technology

## Cook Quench Chill

Designed to cook rice, vegetable and pasta products automatically.

- All stainless steel design
- Microprocessor control
- Stored recipes
- Easy to use HMI
- Trending
- E-terminal data logging (*optional*)
- Euro bin lift (*optional*)
- Vibrating out feed chute



- Model 3000 : 500 litre vessel capacity (water) 200 litre basket capacity
- Model 3001 : 750 litre vessel capacity (water) 300 litre basket capacity
- Basket Mesh Size: 3mm (1.5mm for rice)
- Both models can be fitted with two or three vessels

**DCN On-Site Test Kitchen Facility Available for Product Development, Trials & Hire**

**Book Your Trial Now!**



**For further details and for the full range of DCN food processing equipment contact:**

Sales Office, D C Norris & Company Ltd,

Tel: +44 (0)1767 677 515 Fax: +44 (0) 1767 677956

Email: [sales@dcnorris.co.uk](mailto:sales@dcnorris.co.uk)

Or visit our web-site [www.dcnorris.co.uk](http://www.dcnorris.co.uk)

# D C Norris & Company

At the forefront of food handling and process technology

## Technical Data

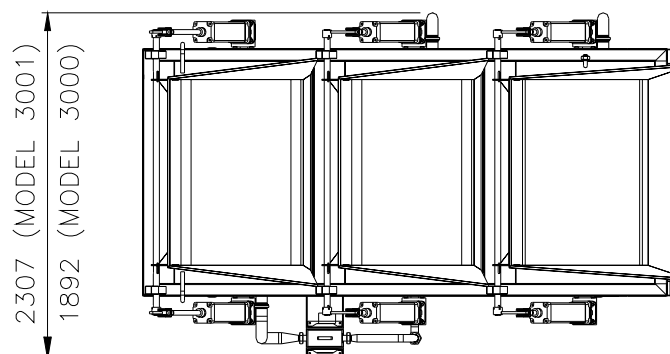
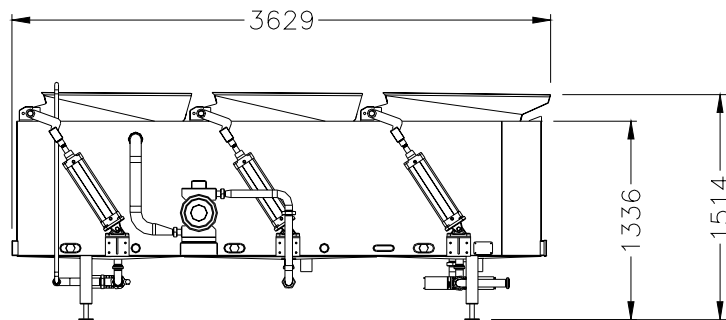

	Requirement	Connection
Steam	750 kg/hr @ 4.5 Bar	2" BSP
Water(tonn)	250 l/min	1 1/2" RJT
Water(cooling)	4500 l/hr	
Air	600 l/min @ 6 Bar	1/2" BSP
Voltage	400 VAC-25A	20mm

Height	Width	Length	Weight (Kg)
1514	3000 – 1892 3001 – 2307	3629	1010

**DCN On-Site Test Kitchen Facility Available for Product Development, Trials & Hire**

**Book Your Trial Now!**



**For further details and for the full range of DCN food processing equipment contact:**

Sales Office, D C Norris & Company Ltd,

Tel: +44 (0)1767 677 515 Fax: +44 (0) 1767 677956

Email: [sales@dcnorris.co.uk](mailto:sales@dcnorris.co.uk)

Or visit our web-site [www.dcnorris.co.uk](http://www.dcnorris.co.uk)