

D C Norris & Company

At the forefront of food handling and process technology

In-Line Homogeniser

Unit used in conjunction with the DCN Steam Jacketed Kettle – emulsifies, homogenises, solubilises, suspends & disperses solids.

- DCN standard unit with high speed mixing head
- Manufactured in stainless steel
- Operating pressure - 100 psi max
- Viscosity - PT 500 cps
- Pumping temperature - 100°C max
- Flooded suction
- 2800 RPM max speed
- 3" RJT inlet and 2" RJT outlet
- Single mechanical seal
- 7.5kW motor
- Optional heads and cutters for achieving different levels of homogenisation

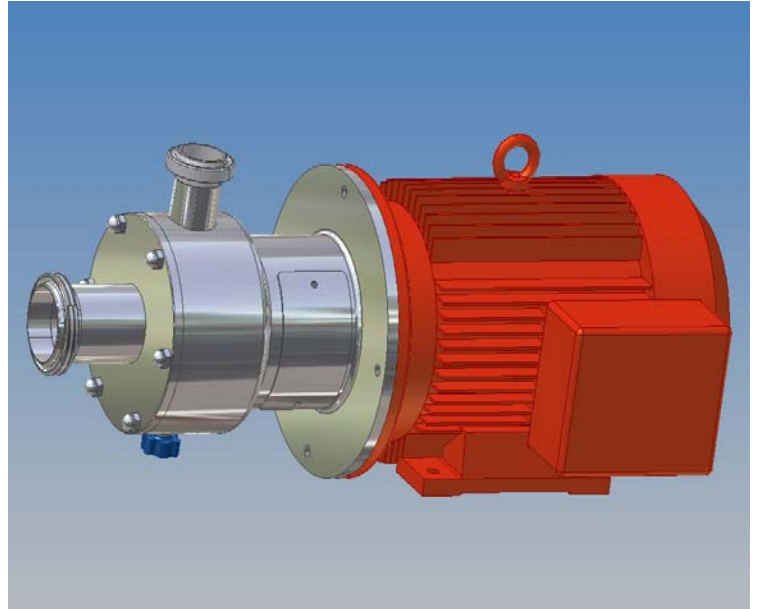

DCN Norris High Performance In-Line Homogeniser mounted on support stand with electrical controls and interfaced with your existing recipe system.

The operation would be via a pneumatic actuated three way 3" plug valve mounted in the kettle discharge pipe work to work in conjunction with the kettle outlet valve and when homogenisation is required, re-circulate the product back into the kettle through a 2" inlet fabricated in the kettle lid.

DCN On-Site Test Kitchen Facility Available for Product Development, Trials & Hire

Book Your Trial Now!



For further details and for the full range of DCN food processing equipment contact:

Sales Office, D C Norris & Company Ltd,

Tel: +44 (0)1767 677 515 Fax: +44 (0) 1767 677956

Email: sales@dcnorris.co.uk

Or visit our web-site www.dcnorris.co.uk

D C Norris & Company

At the forefront of **food** handling and **process** technology

Technical Data

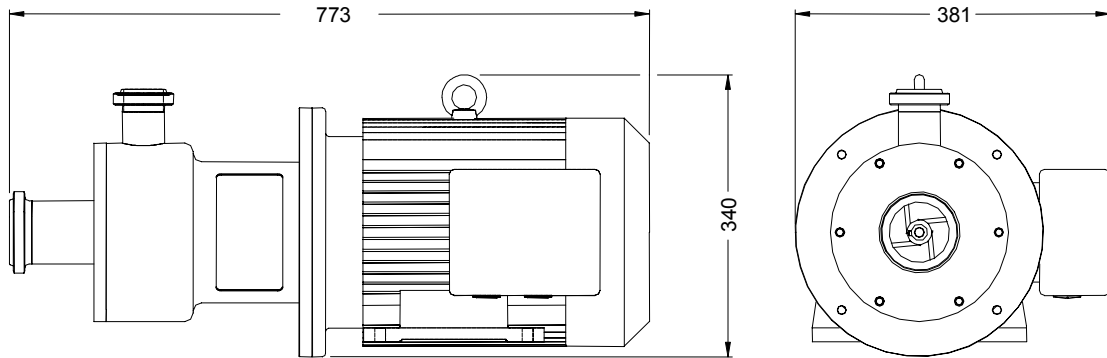

Voltage	Requirement
7.5 kw	415vac – 15.2A

Height	Width	Length	Weight (Kg)
340	381	773	110

DCN On-Site Test Kitchen Facility Available for Product Development, Trials & Hire

Book Your Trial Now!



For further details and for the full range of DCN food processing equipment contact:

Sales Office, D C Norris & Company Ltd,

Tel: +44 (0)1767 677 515 Fax: +44 (0) 1767 677956

Email: sales@dcnorris.co.uk

Or visit our web-site www.dcnorris.co.uk