

D C Norris & Company

At the forefront of food handling and process technology

JET COOK

Cooks, Mixes, Entrains, Holds Using New In-Vessel Jet Cooking System,

- * Fastest Cooking Times on the Market Today
- * High Quality Product
- * Great Taste, Texture, Appearance
- * Reduced Costs
- * Reduced Cleaning Times
- * Elimination of Burn-on
- * Total Incorporation of Powder Ingredients
- * No Noise Pollution

New Patent Applied
for Globe Head
Ideal for Vegetables,
Pasta and I.Q.F Products



Recent Trials in our Test Kitchen have produced outstanding results with a wide variety of products including:

Soups, Sauces, Ready Meals, Rice, Pasta, Dressings, Dips, Ethnic Foods, Jams & Desserts

Book Your Trial Now.....



For further details and for the full range of DCN food processing equipment contact:

Sales Office, D C Norris & Company Ltd,
Tel: +44 (0)1767 677 515 Fax: +44 (0) 1767 677956
Email: sales@dcnorris.co.uk
Or visit our web-site www.dcnorris.co.uk

Technical Data

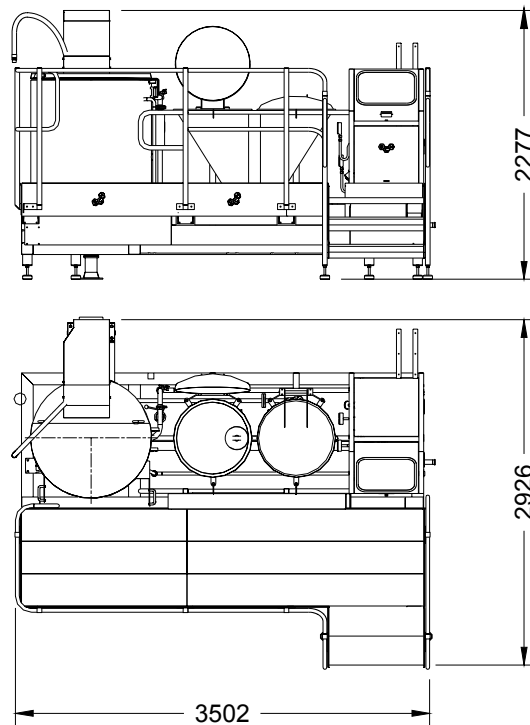

Jet Cook 50 Timings with 0.5mm gap and 6 Barg dry sat steam

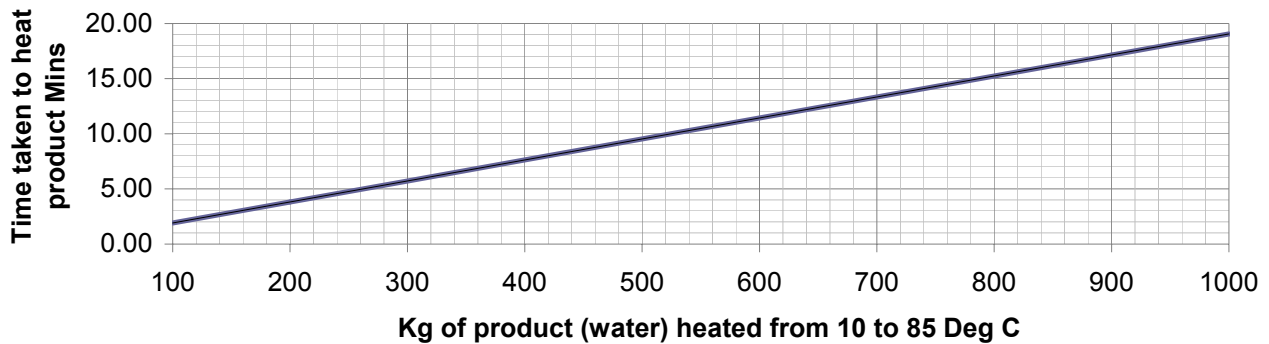

For further information please contact:

D C Norris & Company Ltd

Industrial Estate, Great Gransden

Nr Sandy, Beds, SG19 3AH

Tel: 00 44 (0)1767 677515

Fax: 00 44 (0) 1767 677956

Email: mail@dcnorris.co.uk

www.dcnorris.co.uk

These timing have been recording using The DCN Standard Jet Cook 50
Faster Times can be achieved using 2 units

