

D C Norris & Company

At the forefront of food handling and process technology

Tornado Air Agitation System

Gentle agitation system designed for keeping products in suspension & even distribution. Used in conjunction with DCN Steam Jacketed Kettles & Holding Tanks.

- No product damage - ideal for delicate ingredients
- No moving parts
- Low air consumption for high product movement using unique coander technology
- Variable flow patterns possible
- Lower cost than existing mechanical alternatives
- Strip cleanable
- Patent applied for

Suitable for:

- soups
- sauces
- ready meals
- preserves
- dips
- desserts
- lotions

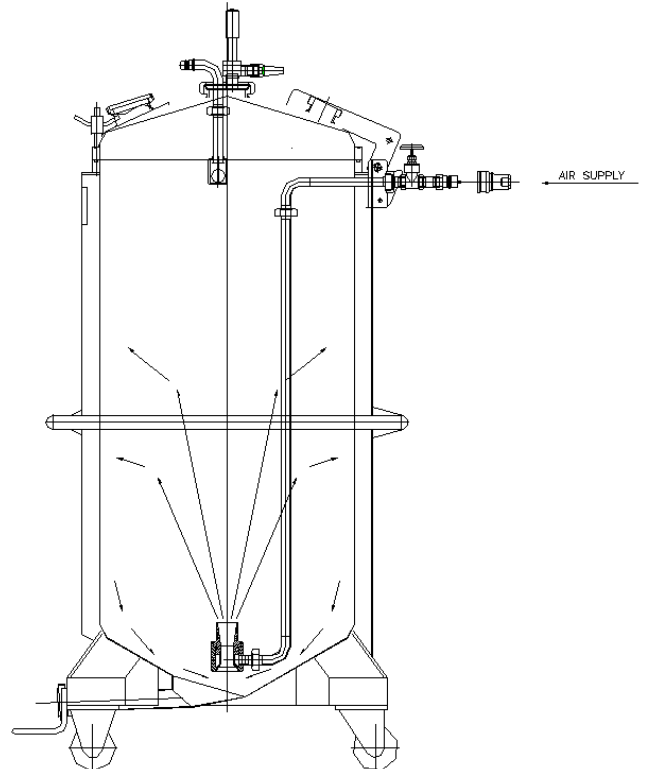

All components are manufactured in the UK.

We offer Quality By Design

DCN On-Site Test Kitchen Facility Available for Product Development, Trials & Hire

Book Your Trial Now!



For further details and for the full range of DCN food processing equipment contact:

Sales Office, D C Norris & Company Ltd,

Tel: +44 (0)1767 677 515 Fax: +44 (0) 1767 677956

Email: sales@dcnorris.co.uk

Or visit our web-site www.dcnorris.co.uk