

D C Norris & Company

At the forefront of food handling and process technology

Wok Style Braising Pan

High Temperature Braising Pan used for frying/cooking/simmering – ideal for small batch ethnic/ready meals

- All stainless steel construction
- Up to 4.5 bar steam pressure
- Tilt both ways (*high low risk*)
- Programmable agitation
- Variable speed
- Temperature logging (*optional*)
- 150 litre capacity
- Easy remove agitator
- Stainless steel or plastic blades
- CE Compliant
- Typical Boiling Time - ambient to boiling 8 mins approx. (4.5 bar steam)

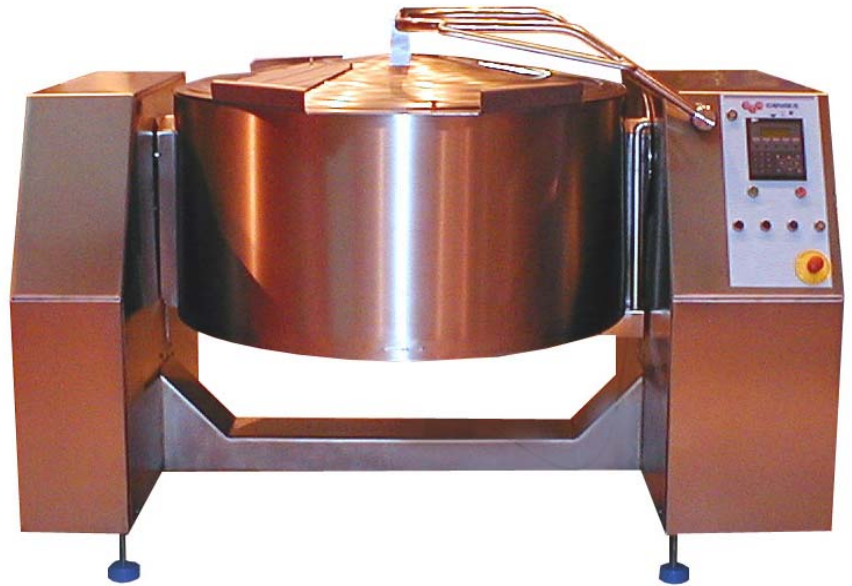

The DCN Model 2700 Wok is a versatile, high performance steam jacketed braising pan, capable of reaching high temperatures in half the time of conventional kettles.

The Wok can be used for either frying or conventional cooking / simmering.

It is perfect for the preparation of small batch Ethnic or Ready Meal foods types.

DCN On-Site Test Kitchen Facility Available for Product Development, Trials & Hire

Book Your Trial Now!



For further details and for the full range of DCN food processing equipment contact:

Sales Office, D C Norris & Company Ltd,

Tel: +44 (0)1767 677 515 Fax: +44 (0) 1767 677956

Email: sales@dcnorris.co.uk

Or visit our web-site www.dcnorris.co.uk

D C Norris & Company

At the forefront of food handling and process technology

Technical Data

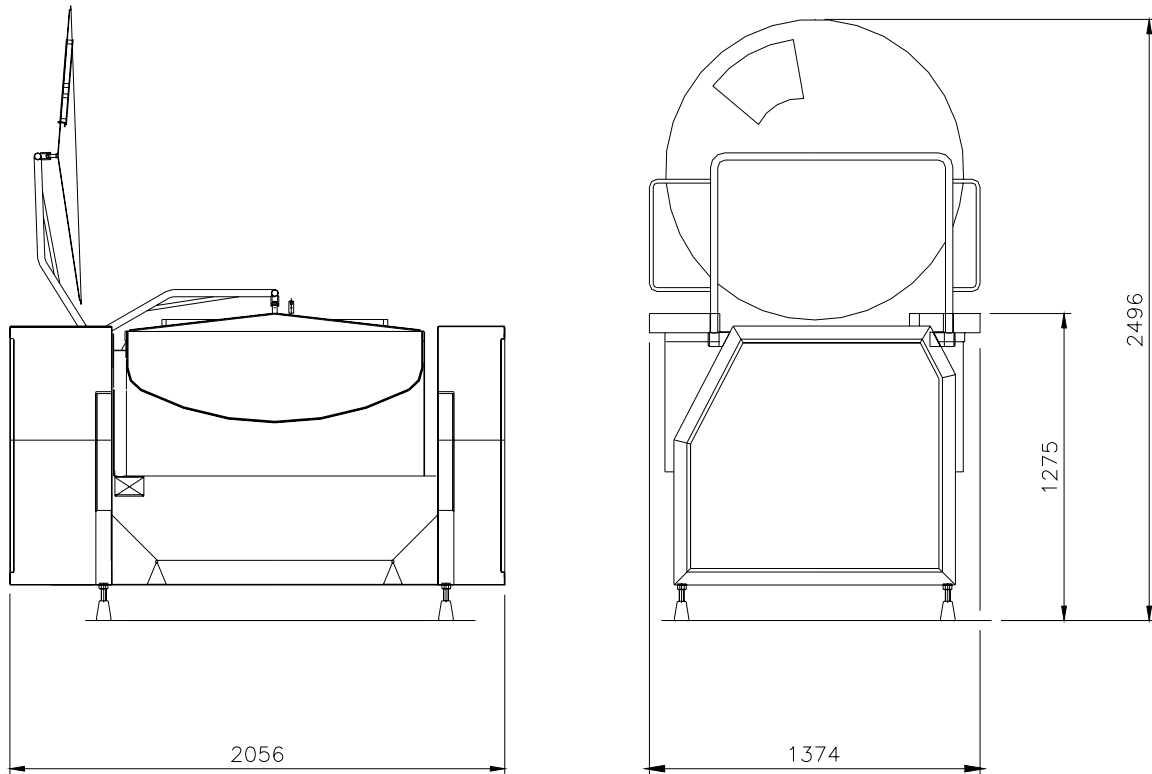

	Requirement	Connection
Voltage	400 Vac 3 phase & neutral - 25 amps	20mm
Steam	300 kg/hr @ 7 Bar	1 1/2" BSP
Air	13.5 l/min @ 6 Bar	8mm

Height	Width	Length	Weight (Kg)
2496 lid open	1374	2056	750

DCN On-Site Test Kitchen Facility Available for Product Development, Trials & Hire

Book Your Trial Now!



For further details and for the full range of DCN food processing equipment contact:

Sales Office, D C Norris & Company Ltd,

Tel: +44 (0)1767 677 515 Fax: +44 (0) 1767 677956

Email: sales@dcnorris.co.uk

Or visit our web-site www.dcnorris.co.uk