

D C Norris & Company

At the forefront of food handling and process technology

LOBE PUMP DEPOSITOR

Designed to accurately portion liquid and semi liquid products at high speed, with minimal product damage.

- Stainless steel lobes
- Twice as fast as piston type (No recharge time)
- HMI display with micro processor control
- Variable speed
- Fully height adjustable
- Single or multiple shot
- Manual or automatic operation
- Typical deposits between 20 and 200 grams with speeds up to 40 packs per min (dependant on deposit size)
- Various nozzles are available for spot or layering of product
- Pressure fed from our transfer vessels or via standard hopper
- Stainless steel construction with all food contact parts being strip cleanable without tools



Optional head sizes and shapes are available making it ideal for fruit, soups, sauces and ready meal type products.



For further details and for the full range of DCN food processing equipment contact:

Sales Office, D C Norris & Company Ltd,

Tel: +44 (0)1767 677 515 Fax: +44 (0) 1767 677956

Email: sales@dcnorris.co.uk

Or visit our web-site www.dcnorris.co.uk

D C Norris & Company

At the forefront of food handling and process technology

Technical Data

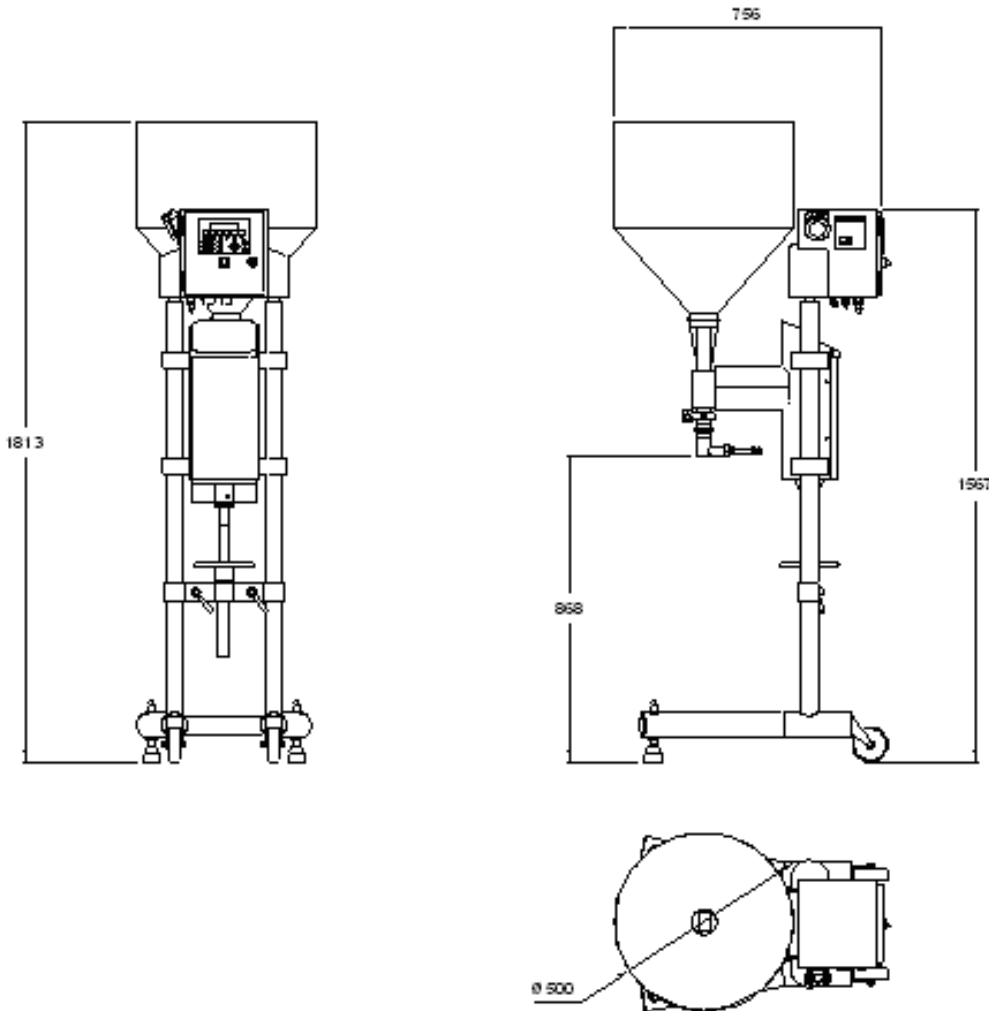

	Pressure	Connection
Compressed Air	90psi	8mm
Voltage	240v (6A)	

Height	Depth
1813	756

DCN On-Site Test Kitchen Facility Available for Product Development, Trials & Hire

Book Your Trial Now!



For further details and for the full range of DCN food processing equipment contact:

Sales Office, D C Norris & Company Ltd,

Tel: +44 (0)1767 677 515 Fax: +44 (0) 1767 677956

Email: sales@dcnorris.co.uk

Or visit our web-site www.dcnorris.co.uk