

D C Norris & Company

At the forefront of food handling and process technology

975 Manual Can-Crusher

- All stainless steel construction
- Manually operated
- Pneumatically powered
- Minimal controls for ease of use
- Fully interlocked for safety
- Completely hose proof design
- Mounted on four adjustable legs each with bolt down facility
- Manual can rinse facility (option)
- Crushed can bin (option)
- Versions available for most can sizes
- Totally pneumatic and mechanical models also available



The Model 975 manually operated pneumatic Can Crusher has been specifically designed for the purpose of crushing empty cans opened using a Model 150 Can Opener.

The empty cans are hand fed into the crushing chamber, when the guard is lowered the can is crushed to approximately 25% of its original height. The guard is then raised and the next can inserted into the chamber, the previous can is automatically displaced out the back of the chamber and into a collection bin (option) for disposal.

DCN On-Site Test Kitchen Facility Available for Product Development, Trials & Hire

Book Your Trial Now!



For further details and for the full range of DCN food processing equipment contact:

Sales Office, D C Norris & Company Ltd,

Tel: +44 (0)1767 677 515 Fax: +44 (0) 1767 677956

Email: sales@dcnorris.co.uk

Or visit our web-site www.dcnorris.co.uk

D C Norris & Company

At the forefront of **food** handling and **process** technology

Technical Data

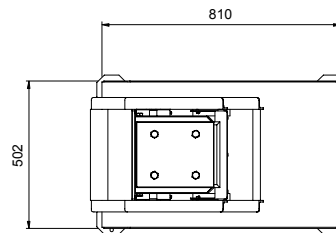
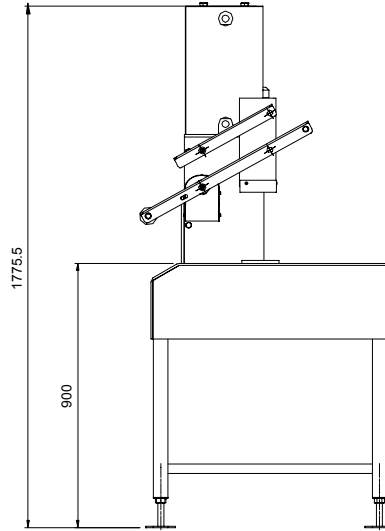
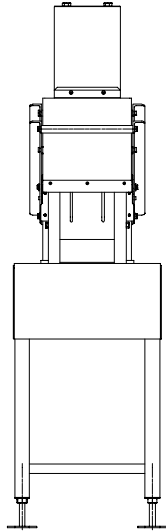

	Pressure	Connection
Compressed Air	240 l/min @ 6 Bar	1/2" BSP
Water	3 Bar	1/2" BSP

DCN On-Site Test Kitchen Facility Available for Product Development, Trials & Hire

Book Your Trial Now!



For further details and for the full range of DCN food processing equipment contact:

Sales Office, D C Norris & Company Ltd,

Tel: +44 (0)1767 677 515 Fax: +44 (0) 1767 677956

Email: sales@dcnorris.co.uk

Or visit our web-site www.dcnorris.co.uk