

D C Norris & Company

At the forefront of food handling and process technology

Transportable Holding Vessels

D C Norris Transportable Holding Vessels – ideal for milk, yoghurt, sauces, fruit pressings, dips, etc.

- Stainless steel grade 316 / 304
- Standard sizes 500 litre to 1000 litre (other sizes available)
- Stackable or non-stackable models available
- Designed to PD5500:2003
- Working pressure 1 bar (or to suit customer requirements)
- Hygienic butterfly valve (size to suit customer requirements)
- Ribbed for strength
- Protection ring on top
- Custom made to requirements



Stackable vessels can be stacked three high when empty or two high when full.

Other types of vessel available include: mobile, insulated, hot-fill, glycol jacketed, square – please contact the Sales Office for further information.

DCN On-Site Test Kitchen Facility Available for Product Development, Trials & Hire

Book Your Trial Now!



For further details and for the full range of DCN food processing equipment contact:

Sales Office, D C Norris & Company Ltd,

Tel: +44 (0)1767 677 515 Fax: +44 (0) 1767 677956

Email: sales@dcnorris.co.uk

Or visit our web-site www.dcnorris.co.uk

D C Norris & Company

At the forefront of food handling and process technology

Technical Data

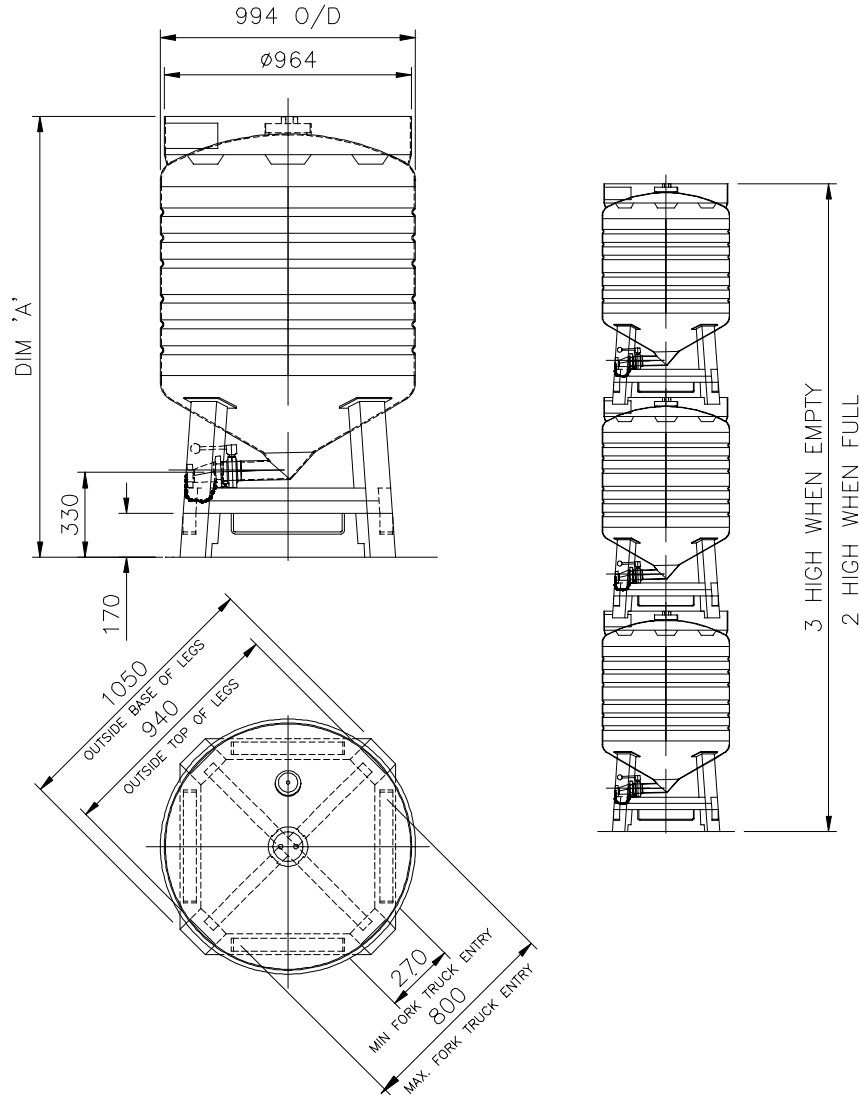

Capacity	500 Litre	600 Litre	700 Litre	800 Litre	900 Litre	1000 Litre
Dim 'A'	1337	1468	1599	1730	1861	1992

DCN On-Site Test Kitchen Facility Available for Product Development, Trials & Hire

Book Your Trial Now!



For further details and for the full range of DCN food processing equipment contact:

Sales Office, D C Norris & Company Ltd,

Tel: +44 (0)1767 677 515 Fax: +44 (0) 1767 677956

Email: sales@dcnorris.co.uk

Or visit our web-site www.dcnorris.co.uk