

D C Norris & Company

At the forefront of food handling and process technology

MOBILE HOLDING/TRANSFER VESSELS

- Stainless steel grade 316 / 304
- Standard sizes 300 litre to 500 litre (other sizes available)
- Designed to PD5500:2003
- Working pressure 1 bar (or to suit customer requirements)
- Tested to 25" vacuum
- Hygienic butterfly valve (size to suit customer requirements)
- Hinged lid
- Insulated / jacketed
- Agitated or non-agitated models available
- Custom made to customer requirements
- Other types of vessel available



DCN On-Site Test Kitchen Facility Available for Product Development, Trials & Hire

Book Your Trial Now!



For further details and for the full range of DCN food processing equipment contact:

Sales Office, D C Norris & Company Ltd,

Tel: +44 (0)1767 677 515 Fax: +44 (0) 1767 677956

Email: sales@dcnorris.co.uk

Or visit our web-site www.dcnorris.co.uk

D C Norris & Company

At the forefront of food handling and process technology

TECHNICAL DATA

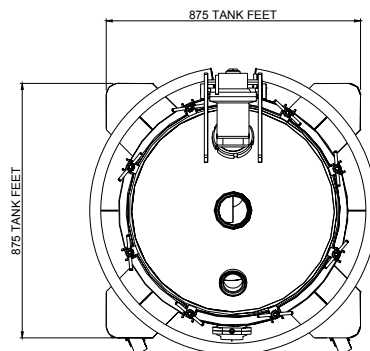
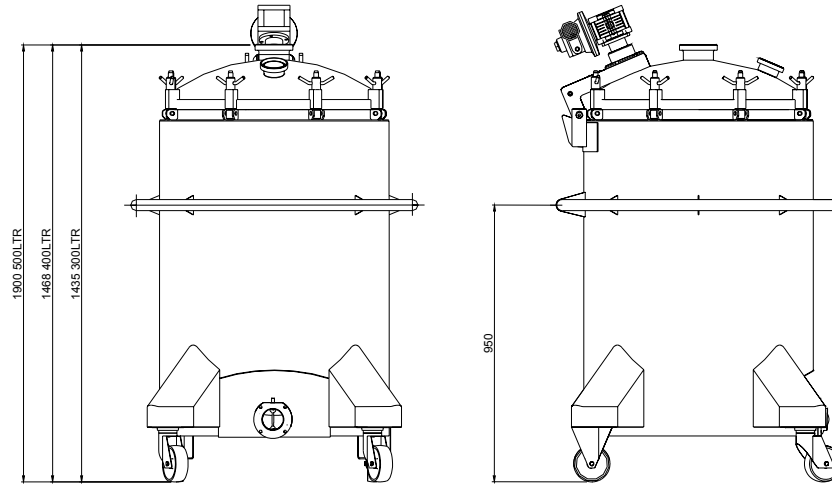

Capacity	300 Litre	400 Litre	500 Litre
Dim 'A'	1435	1468	1900

DCN On-Site Test Kitchen Facility Available for Product Development, Trials & Hire

Book Your Trial Now!



For further details and for the full range of DCN food processing equipment contact:

Sales Office, D C Norris & Company Ltd,

Tel: +44 (0)1767 677 515 Fax: +44 (0) 1767 677956

Email: sales@dcnorris.co.uk

Or visit our web-site www.dcnorris.co.uk